

Product Specifications



Product : F.O. 10G SFP+ Duplex LC Transceiver, SMF 1550nm 40km

Features <ul style="list-style-type: none"> • Up to 11.3Gbps Data Links • EML transmitter and PIN receiver • Duplex LC receptacle optical interface compliant • Single +3.3V power supply • Power dissipation < 1.4 W • Hot-pluggable • Operating temperature range: Commercial: 0°C~+70°C • Industry: -40°C~+85°C • RoHS Compliant • 2-wire interface with integrated Digital Diagnostic monitoring • Up to 40km transmission distance over Single Mode Fiber(SMF) 	Application <ul style="list-style-type: none"> • 10GBASE-ER/EW & 10G Ethernet • 10G Fiber Channel Standard <ul style="list-style-type: none"> • Compliant with MSA SFP+ specification(SFF-8431) • Compliant with SFF-8472 • Compliant to IEEE 802.3ae
--	---

Specification

Absolute Maximum Ratings				
Parameter	Symbol	Min	Max	Unit
Storage temperature	TS	-40	85	°C
Power Supply Voltage	Vcc3	-0.5	+4	V
Relative Humidity	RH	5	95	%
Signal Input Voltage		Vcc-0.3	Vcc+0.3	V

Recommended Operating Conditions					
Parameter	Symbol	Min	Typical	Max	Unit
Operating Case Temperature (Commercial)	Tc	0		70	°C
Operating Case Temperature (Industrial)		-40		85	
Power Supply Voltage	Vcc3	3.13	3.3	3.47	V
Supply Current	Icc3			360	mA
Data Rate			10.3125		Gbps
Fiber Length 9/125µm core SMF		-	40	-	km

Electrical Characteristics

Parameter	Symbol	Min	Max	Unit	Notes
Transmitter differential input voltage	Vin,pp	180	700	mW	
Receiver differential output voltage	Vout,pp	300	850	mW	
Transmit disable voltage	VIH	2	Vcc	V	LVTTL
Transmit enable voltage	VIL	Vee	Vee+0.8	V	LVTTL
Loss of Signal (LOS)	Voh	2	Vcc	V	LVTTL
	Vol	Vee	Vee+0.8	V	LVTTL

Optical transmitter Characteristics

Parameter	Symbol	Min	Typical	Max	Unit	Notes
Launched Power (avg.)	Pout	-1		4	dBm	
Operating Wavelength Range	λ_c	1530	1550	1570	nm	
Spectral Width	$\Delta\lambda$			1	nm	
Side Mode Suppression Ratio	SMSR	30			dB	
Extinction Ratio	ER	8.2			dB	2
Transmitter and Dispersion Penalty	TDP			2	dB	
Relative Intensity Noise	RIN			-128	dB/Hz	
Optical Rise/Fall Time	Tris/Tfall	28			PS	3
Optical Tx Output disable	Pdis			-30	dBm	
Output Eye Diagram	Compliant with ITU-T G.691 eye mask and IEEE802.3ae eye mask					

Optical receiver Characteristics

Parameter	Symbol	Min	Typical	Max	Unit	Notes
Receiver Sensitivity	S			-16	dBm	4
Wavelength Range	λ_c	1270		1610	nm	
Receiver Reflectance				-12	dB	
Optical Power Input Overload	Pin-max	0.5			dBm	4
LOS	Optical De-assert	Pd		-17	dBm	4
	Optical Assert	Pa	-30			
LOS hysteresis		0.5	1		dB	5

Notes

- The supply current is SFP+ module’s working current.
- For the measurements, the device was driven with 10.3125Gbps data pattern with $2^{31}-1$ PRBS payload.
- Optical transition time is the time interval required for the rising or falling edge of an optical pulse to transition between the 20% and 80% amplitudes relative to the logical 1 and 0 levels.
- Measured with a PRBS $2^{31}-1$ test pattern, @10.3125Gbps, ER=8.2dB, BER< 10^{-12} .
- The LOS Hysteresis minimizes ‘chatter’ on the output line. In principle, Hysteresis alone does not guarantee chatter-free operation.

Pin Descriptions

Figure 1 SFP+ Pad assignment Top View

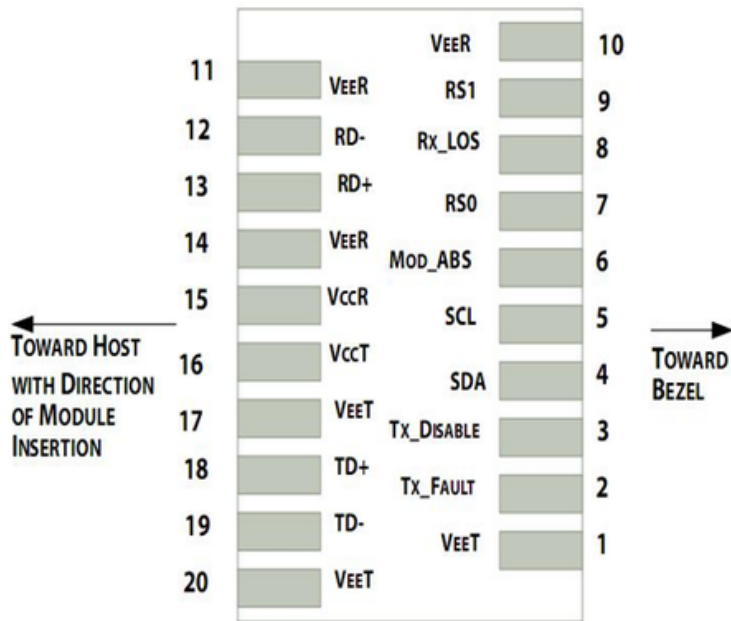

Figure 2 SFP+ Module ContactAssignments



Pin	Power Seq.	Symbol	Function/Description	Ref.
1	1st	VeeT	Module Ground(Common with Receiver Ground)	1
2	3rd	TX Fault	Transmitter Fault, Low: normal; High: abnormal	2
3	3rd	TX Disable	Transmitter Disable High: Transmitter off Low: Transmitter on	3
4	3rd	SDA	2-Wire SerialInterface Data Line (Same as MOD-DEF2 in INF-8074i)	4
5	3rd	SCL	2-Wire SerialInterface Data Line (Same as MOD-DEF2 in INF-8074i)	4
6	3rd	Mod_ABS	Module Absent, Connect to VeeT or VeeR in Module	5
7	3rd	RS0	Rate Select 0, optionally controlsSFP+ module receiver	6
8	3rd	RX_LOS	Receiver Loss ofSignal indication High: loss of signal Low: signaldetected	7
9	3rd	RS1	Rate Select 1, optionally controls SFP+ module transmitter	8
10	1st	VeeR	Receiver Ground	1
11	1st	VeeR	Receiver Ground	1
12	3rd	RD-	Receiver InvertedDATA out. AC Coupled. CML-O	9
13	3rd	RD+	Receiver Non-inverted DATA out. AC Coupled. CML-O	9
14	1st	VeeR	Receiver Ground	1
15	2nd	VccR	Receiver Power Supply	10
16	2nd	VccT	Transmitter Power Supply	10
17	1st	VeeT	Transmitter Ground	1
18	3rd	TD+	Transmitter Non-Inverted DATA in. AC Coupled. CML-I	11
19	3rd	TD-	Transmitter Inverted DATA in. AC Coupled.CML-I	11
20	1st	SDA	Transmitter Ground	1

Notes

- The module signal ground contacts.
- This pin is an open drain/collector and should be pulled up to Vcc-host in the host with a 4.7k~10k Ohm resistor.
- This pin should be pulled up to Vcct with a 4.7k~10k Ohm resistor in modules.
- SDA&SCL (IIC) are needed pull up 4.7k~10k Ohm resistors on host board.
- Mod_ABS is connected to VeeT or VeeR in the SFP+ module.
- Rate Select 0, Optionally controls SFP+ module receiver , High: RX input signaling rate > 4.25GBd and Low: RX input signaling rates ≤ 4.25GBd.
- Module RX_Los of signal indication need pull up 4.7k~10k Ohm resistor on host board.
- Rate Select 1, Optionally controls SFP+ module transmitter, High: Tx input signaling rate > 4.25GBd and Low : Tx input signaling rates ≤ 4.25GBd.
- RD -/+ : These are the differential receiver outputs. They are CML AC-coupled with 100 Ohm terminal resistor matching internal.
- VccR and VccT are the receiver and transmitter power supplies.
- TD -/+ : These are the differential transmitter inputs. They are CML AC-coupled with 100 Ohm terminal resistor matching internal.

Block Diagram

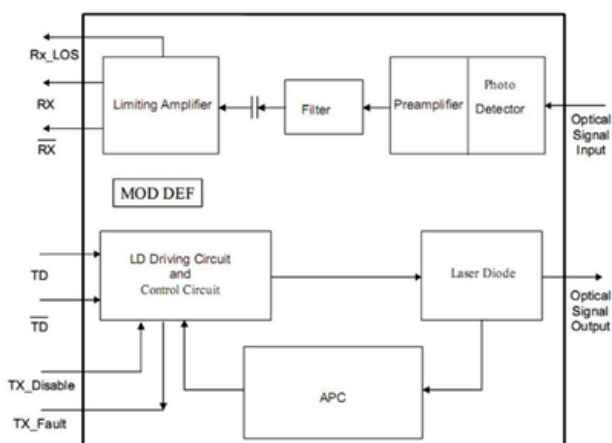

Digital Diagnostic Memory Map

2 wire address 1010000X (A0h)

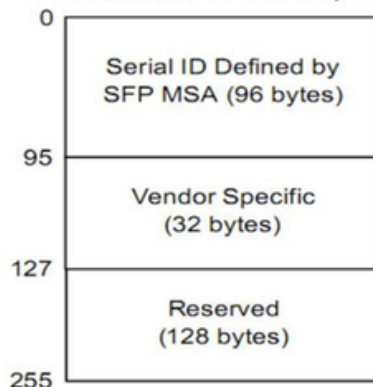

2 wire address 1010001X (A2h)

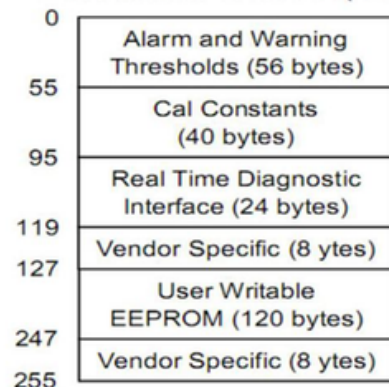

Package Outline

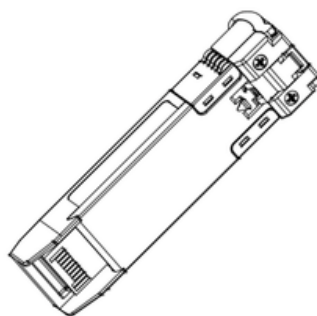
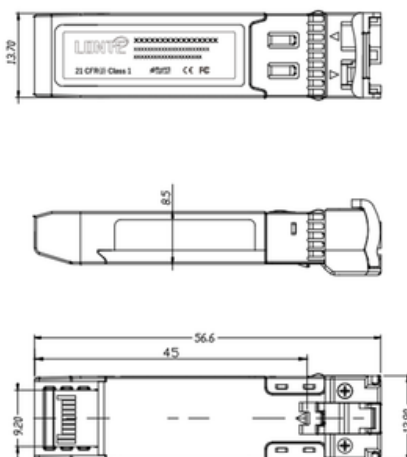

All dimensions are ±0.2mm unless otherwise specified.
Unit: mm

Regulatory Compliance

Feature	Test	Method
Electrostatic Discharge (ESD) to the Electrical Pins	<ul style="list-style-type: none">MIL-STD-883EMethod 3015.7	Class 1(>1000V for SFI pins, >2000V for other pins.)
Electrostatic Discharge (ESD) Immunity	<ul style="list-style-type: none">IEC61000-4-2	Class 2(>4.0kV)
Electromagnetic Interference (EMI)	<ul style="list-style-type: none">CISPR22 ITE Class BFCC Class BCENELEC EN55022VCCI Class 1	Comply with standard
Immunity	<ul style="list-style-type: none">IEC61000-4-3	Comply with standard
Eye Safety	<ul style="list-style-type: none">FDA 21CFR 1040.10 and 1040.11EN (IEC) 60825-1,2	Compatible with Class I laser Product

Revision record

Date	version	change Description
May 5, 2026	V.0	First release